

35/40/45D-9S 50D-9SA

Diesel Counterbalance Trucks

MOVING YOU FURTHER

HYUNDAI CONSTRUCTION EQUIPMENT



■ Some of the photos may include optional equipment.

 **HYUNDAI**
CONSTRUCTION EQUIPMENT

PLEASE CONTACT

www.hyundai-ce.com

2017. 03 Rev. 4

 **HYUNDAI**
CONSTRUCTION EQUIPMENT

Your satisfaction is our priority!

Hyundai introduces a new line of 9-series diesel forklift trucks.

The newly designed 4 wheel counterbalance trucks provide every operator comfortable driving, increased productivity and easy maintenance.

New Diesel Forklift with Proven Quality and Advanced Technology

- Maximum performance
- Spacious operator's cab
- 5.6 inch LCD color monitor
- Truck inclination warning system
- Load weight indicator (Optional)
- OPSS System for safe operation (Optional)
- Easy serviceability



*Some of the photos may include optional equipment.

High Efficiency & Optimal Performance



Powerful engine and high technology systems provide you with enhanced performance and highest productivity.

35/40/45D-9S
50D-9SA



*Some of the photos may include optional equipment.



HYUNDAI D4DD Engine 70kW/2,300rpm

High Power Engine - HMC D4DD

Market approved quality of HMC D4DD engine ensures incomparable performance, durability and excellent fuel efficiency. This engine meets EPA Tier-III and EU stage IIIA emission regulations.



Highly Durable Transmission

Powershift transmission of forward 2 stages and reverse 2 stages provides fast travel speed and quiet travel under any heavy load condition, and enhances work efficiency. The clutch protection system prevents excessive use of inching as well as minimizes change-impact.



Highly Durable Drive Axle

The strengthened drive axle separable from transmission ensures low vibration and easy maintenance. The wet disc type brake is applied for easy operation, smooth response and maintenance free.



Boosting Type Brake Valve

The boosting type brake valve is applied for strong braking performance.



Integrated Wheel Rim

The integrated wheel rim provides significantly increased service life.



Fully Hydrostatic Power Steering

The hydraulic steering system always guarantees smooth and flexible steering, preventing over-run and kick-back.



Travel Speed (MAX)

Model	km / h
35D-9S	27.6
40D-9S	26.7
45D-9S	26.7
50D-9SA	26.6

Gradeability (MAX)

Model	%
35D-9S	41.4
40D-9S	36.9
45D-9S	33.6
50D-9SA	30.7

Faster Travel Speed & Gradeability

The powerful high-output engine provides greater acceleration, better gradeability and faster travel speed on any tough terrain or slope.

Best Convenience & Optimized Ergonomics



The ergonomically designed cabin and the new style LCD color monitor provides full support and comfort to the operator.

35/40/45D-9S
50D-9SA



*Some of the photos may include optional equipment.

Spacious Operator Cabin

The newly designed cabin provides wide visibility and spacious environment, ensuring all day comfort for the operator.



Optimized Pedal Position

On the 9-series the pedals are mounted to the console to reduce operator fatigue, and noise and dust from the engine compartment.



Low Entrance Height

The low entrance height ensures easy and safe access for the operator.



Adjustable Steering Wheel

To achieve a comfortable drive position, the angle of the steering column can easily be adjusted by a lever on the right-hand side of the steering column.



Grammer Seat (Option)

- Quick Achievement of the Ergonomically Best Sitting Position
- Asymmetrical Backrest
- Movable Armrests
- Seat Heating
- Practical Document Box

Advanced LCD Monitor

The 5.6 inch wide screen LCD color monitor allows the operator to control the machine with ease. The monitor features speed, travel direction, battery discharge indicator and hour meter.

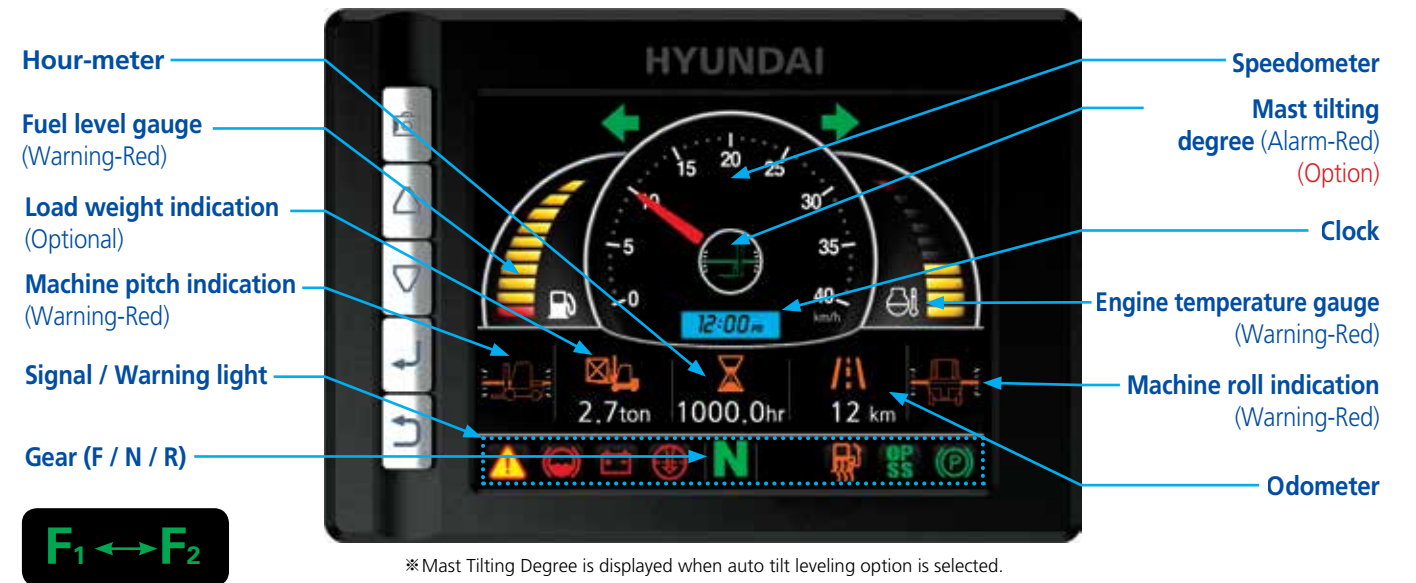

Automatic Gear Box

Automatic transmission is speed controlled:

- During acceleration when the speed reaches 7 km/h second gear is selected .
- When decelerating shift down to first speed is done at 5 km/h.

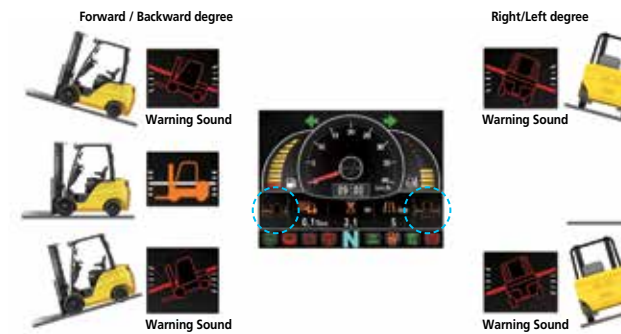

Truck Inclination Warning System

To improve the productivity and safety, the truck inclination warning system will monitor and indicate forward/backward, right/left degree of the forklift. The alarm alerts the operator when the forklift degree is over the ISO standard.

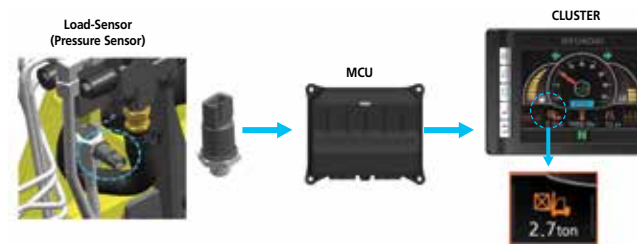

Load Weight Indication System (Optional)

The optional Weight Indicator displays the load weight on the monitor. The load sensor reduces the time to check loaded weight and the alarm alerts the driver when overloaded.

Advanced Safety



The safely designed driver's space makes your operating more comfortable.

35/40/45D-9S
50D-9SA



Excellent Visibility for Safe Operation

Optimized lift cylinder arrangement provides operator with wider visibility. The panoramic mirror expands the driver's view when backing up.

*Some of the photos may include optional equipment.

Fork Safety Features

When the forks are being lowered, a down-control valve maintains the controlled speed. The down-safety valve prevents forks from dropping down in case of sudden damage of hydraulic line.

OPSS (Operator Presence Sensing System)

All mast and drive movements stop functioning when the operator is not in the seat.

- Lift Lock
- Tilt Lock
- Drive Lock



*Some of the photos may include optional equipment.



Strong Overhead Guard

Exceeding CEE and ANSI regulations, the overhead guard offers optimal protection combined with excellent all round visibility.



Safety Lamps & Rear Reflectors

Halogen headlights and rear LED combination lights offer the driver visibility in all circumstances. Rear reflectors mounted on the counterweight enhance safety for the driver and the application.

Fast and Easy Maintenance

An ideal arrangement of components ensures easy access and convenience for maintenance.

35/40/45D-9S 50D-9SA



Some of the photos may include optional equipment.

Large Engine Hood

Highly accessible engine compartment assures fast and efficient maintenance. The enlarged air cleaner(8") has extended service time of engine.



Waterproof & Dustproof Cover

Newly developed Waterproof and Dustproof fuse box and relay box for ease of maintenance.

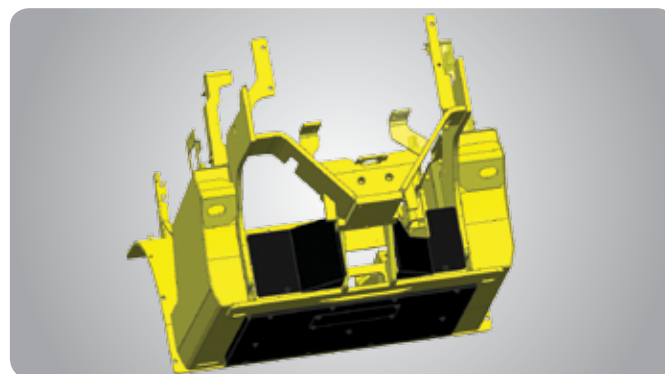

Rear Tire Cover / Under Cover Option

The rear tire cover is well-suited to prevent clogging of the radiator from foreign substances.



Rear View Camera (Optional)



Emergency Switch (Optional)



Maintenance Management Display



Password Starting System (Anti-theft system)



Fuel Cap with Key

*Some of the photos may include optional equipment.

New 9 Series

35/40/45D-9S 50D-9SA

Dimension

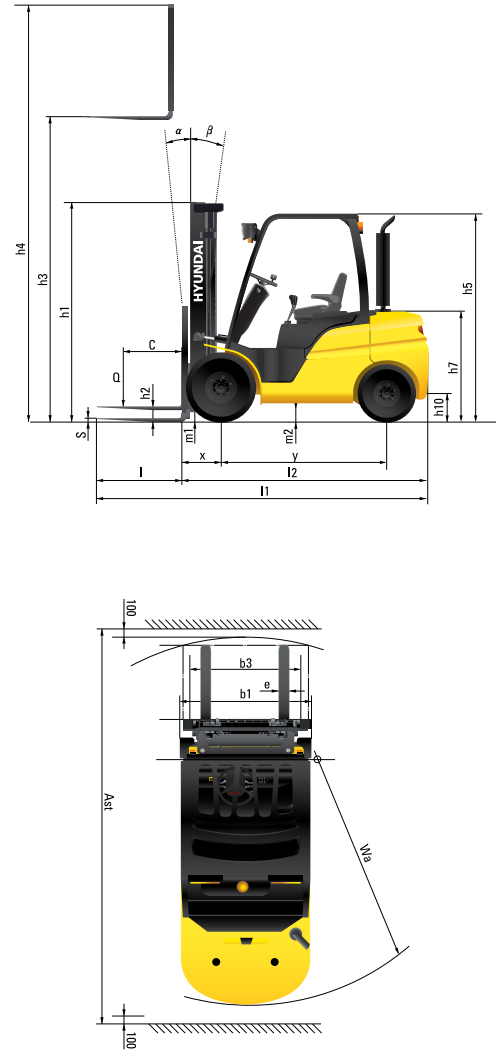

Specification

Identification					
1.1	Manufacturer	Hyundai	Hyundai	Hyundai	Hyundai
1.2	Manufacturer's type designation	35D-9S	40D-9S	45D-9S	50D-9SA
1.3	Drive: electric (battery or mains), diesel, petrol, fuel gas, manual	DIESEL	DIESEL	DIESEL	DIESEL
1.4	Type of operation: hand, pedestrian, standing, seated, order-picker	seated	seated	seated	seated
1.5	Load capacity / rated load	kg 3,500	4,000	4,500	5,000
1.6	Load center distance	c mm 600	600	600	600
1.8	Load distance, center of drive axle to fork	x mm 561	561	561	576
1.9	Wheelbase	y mm 2,000	2,000	2,000	2,000
Weights					
2.1	Service weight	kg 5,892	6,437	6,858	7,329
2.2	Axle loading, loaded front/rear	kg 8,295 / 1,097	9,212 / 1,225	9,998 / 1,360	10,831 / 1,498
2.3	Axle loading, unloaded front/rear	kg 2,765 / 3,127	2,892 / 3,545	2,888 / 3,970	2,931 / 4,398
Wheels, Chassis					
3.1	Tires: solid rubber, superelastic, pneumatic, polyurethane	pneumatic	pneumatic	pneumatic	pneumatic
3.2	Tires size, front	8.25-15x14PR	7.50-16x12PR	7.50-16x12PR	7.50-16x12PR
3.3	Tires size, rear	7.00-12x12PR	7.00-12x12PR	7.00-12x14PR	7.00-12x14PR
3.5	Wheels, number front x rear (x=driven wheels)	2 x 2	4 x 2	4 x 2	4 x 2
3.6	Track width, front	mm 1,132	1,282	1,282	1,282
3.7	Track width, rear	mm 1,140	1,140	1,140	1,140
Basic Dimensions					
4.1	Mast / fork carriage tilt forward / backward (α / β)	degrees 8 / 10	8 / 10	8 / 10	8 / 10
4.2	Lowered mast height	h1 (mm) 2,235	2,220	2,220	2,220
4.3	Free lift	h2 (mm) 120	120	120	120
4.4	Lift height	h3 (mm) 3,020	3,020	3,020	2,930
4.5	Extended mast height	h4 (mm) 4,234	4,234	4,234	4,147
4.7	Overhead load guard (cab) height	h5 (mm) 2,220 (2,360)	2,210 (2,350)	2,210 (2,350)	2,210 (2,350)
4.8	Seat height / standing height	h7 (mm) 1,070	1,070	1,070	1,070
4.12	Coupling height	h10 (mm) 364	364	364	364
4.19	Overall length	l1 (mm) 4,180	4,235	4,455	4,500
4.20	Length to face of forks	l2 (mm) 3,110	3,165	3,235	3,300
4.21	Overall width	b1 (mm) 1,370	1,740	1,740	1,740
4.22	Fork dimensions (hook type)	ℓ / e / s (mm) 1,070 x 122 x 50	1,070 x 150 x 50	1,220 x 150 x 50	1,200 x 150 x 60
4.23	Fork carriage ISO 2328, class / type A, B	III / A	III / A	IV / A	IV / A
4.24	Fork-carriage width	b3 (mm) 1,300	1,600	1,600	1,600
4.31	Ground clearance, loaded, under mast	m1 (mm) 170	155	155	155
4.32	Ground clearance, centre of wheelbase	m2 (mm) 215	205	205	200
4.33	Aisle width for pallets 1,000x1,200 crossways (LxW)	Ast (mm) 4,629	4,676	4,726	4,771
4.34	Aisle width for pallets 800x1,200 lengthways (WxL)	Ast (mm) 4,829	4,876	4,926	4,971
4.35	Turning radius	Wa (mm) 2,868	2,915	2,965	3,010
4.36	Smallest pivot point distance	1,009	1,009	1,009	1,009
Performance Data					
5.1	Travel speed, unloaded	km/h 27.6	26.7	26.7	26.6
5.2	Lift speed, loaded/ unloaded	mm/s 550 / 570	540 / 570	530 / 570	460 / 490
5.3	Lowering speed, loaded/unloaded	mm/s 500 / 500	500 / 500	500 / 500	500 / 500
5.5	Drawbar pull, loaded	kg 3,997	4,018	4,023	4,031
5.7	Gradient performance, loaded	% 41.4	36.9	33.6	30.7
5.9	Acceleration time, loaded/ unloaded(10m)	sec -	-	-	-
5.10	Service brake	hydraulic	hydraulic	hydraulic	hydraulic
Engine					
6.1	Engine manufacturer / type	HMC D4DD	HMC D4DD	HMC D4DD	HMC D4DD
6.2	Engine power acc. to ISO 1585	kW/rpm 70 / 2,300	70 / 2,300	70 / 2,300	70 / 2,300
6.3	Maximum Torque	kgf.m/rpm 35 / 1,600	35 / 1,600	35 / 1,600	35 / 1,600
6.4	No. of cylinder / cubic capacity	anz/cm2 4 / 3,907	4 / 3,907	4 / 3,907	4 / 3,907
Other Details					
8.1	Type of drive control	Power shift 2/2	Power shift 2/2	Power shift 2/2	Power shift 2/2
8.2	Operating pressure (system / attach)	kgf/cm ² 210 / 150	210 / 150	210 / 150	210 / 150
8.3	Oil volume for attachment	ℓ /min 100	100	100	100
8.4	Sound level at driver's ear according to DIN 12 053	db(A) 82	82	82	82

*Specifications and designs are subject to change without advance notice.

Load Capacity

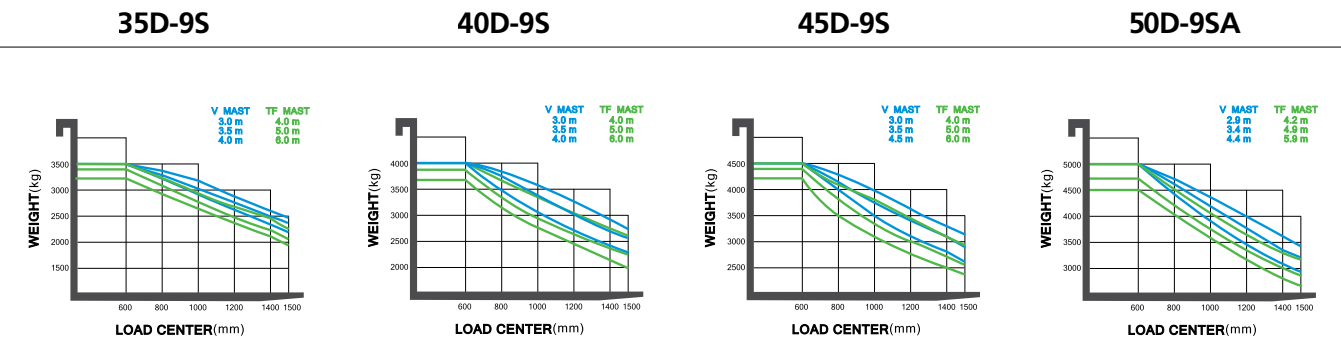

Various Attachments

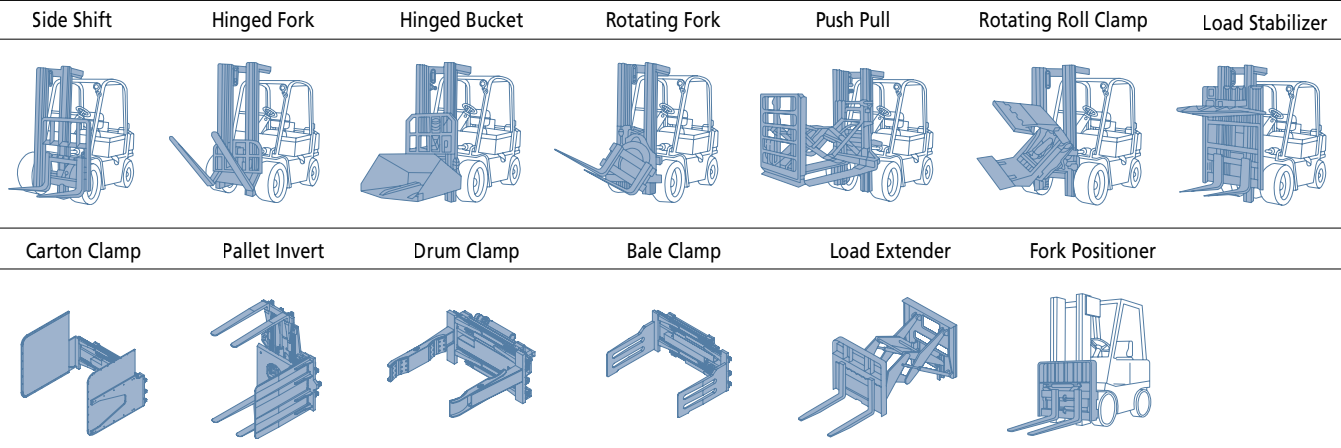

Optional Items

- **Fork(mm)**
35/40D-9S : 1220, 1370, 1520, 1670, 1820, 1970, 2120, 2400
45D-9S : 1070, 1370, 1520, 1670, 1820, 1970, 2200, 2400
50D-9SA : 1350, 1500, 1800, 2000, 2400
- **Overshoe(mm)**
1600, 1800, 2000, 2200
- **Integrated Sideshift, Integrated Fork positioner**
- **Tire** : Pneumatic(STD)/ Solid / Non-marking/
Double Tire(Front tire) 35D-9S : 7.50-16-12PR
Single Tire(Front tire) 40D-9S/45D-9S/50D-9SA : 300-15-18PR
- **Seat** : Arm Rest, Heat, Buckle SW, Backrest Ext
- **M.C.V** : 2-Spool(STD), 3-Spool, 4-Spool, 5-Spool
- **Load Weight Indicator**
- **Beacon Lamp**
- **Rear Work Lamp**

- **OPSS** : Travel, Travel + Mast
- **Cabin** (Heater & Air Conditioner)
- **Rear View Camera**
- **High OHG** (2,340mm)
- **45D-9S** : Class III Fork Carriage
- **Cabin** (Heater & Air Conditioner)
- **Rear View Camera**
- **High OHG** (2,340mm)
- **45D-9S** : Class III Fork Carriage
- **Under Cover**
- **Side Mirror** (LH&RH)
- **Shaft type Carriage**
- **Rain Cover**
- **Extinguisher**